

Owner / Operator's Manual

This Manual Must Be Read Before Operating The Equipment

SNOWEX[®]

LEADERS IN ICE CONTROL

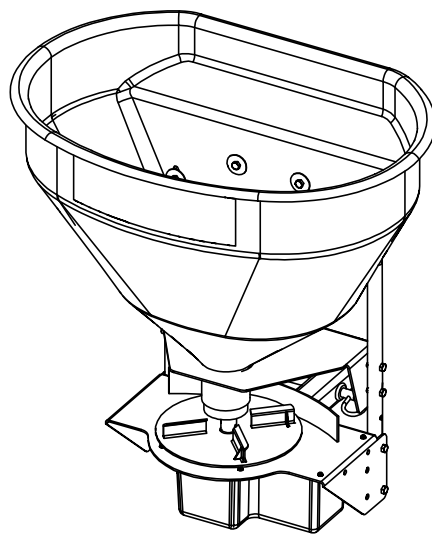
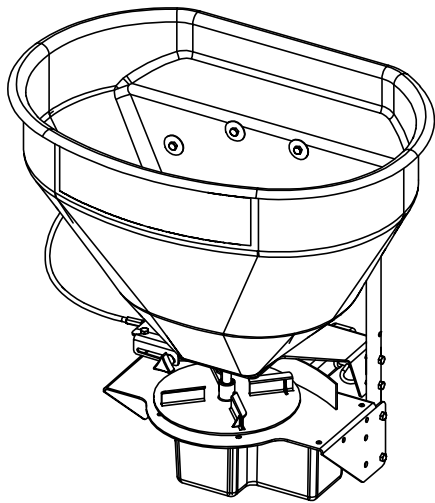

SP-125 / US-100
SP-225 / US-200

TRYNE^{EX}
INTERNATIONAL

CUSTOMER COPY

Madison Heights, Michigan 48071
800-725-8377
www.snowexproducts.com

Table of Contents



INTRODUCTION.....	3
GENERAL INFORMATION AND REGISTRATION	4
SAFETY	5-6
• PREPARATION	
• OPERATIONS	
• SERVICE	
SPREADER PARTS/DIAGRAMS.....	7-12
• SP-125 / US-100 ACCURATE FLOW	
• SP-125 / US-100 ACCURATE FLOW COMPLETE DRIVE ASSEMBLY	
• SP-225 / US-200 MULTI-PURPOSE	
• SP-225 / US-200 MULTI-PURPOSE COMPLETE DRIVE ASSEMBLY	
WIRING INSTRUCTIONS / VAR-020 CONTROL	13-14
• WIRING DIAGRAM	
• VAR-020 CONTROL	
SPREADER MOUNT PARTS/DIAGRAMS	15-20
• UTILITY MOUNT	
• TRAILER MOUNT	
• 3-POINT MOUNT	
• PIVOT PAL HITCH MOUNT	
• DROP UTILITY MOUNT	
OPERATING THE SPREADER	21
BLANK PAGE	22
SPREADER MAINTENANCE	23
TROUBLESHOOTING	24-25
WARRANTY	26-27

Have a question or need assistance?
SnowEx Customer Service
(800) 725-8377

or (586) 756-6555

Monday through Friday 8:00 AM to 4:30 PM EST

Fax: (586) 427-0552

E-Mail: customercare@trynexfactory.com

Website: www.snowexproducts.com

This manual has been designed for your help. It will assist you and instruct you on the proper set-up, installation and use of this spreader. Refer to the table of contents for an outline of this manual.

We require that you read and understand the contents of this manual completely (especially all safety information) before attempting any procedure contained herein. Extra copies of Owner/Operator Manuals can be purchased at your Snowex Dealer.



THIS SIGN SHOULD ALERT YOU:

The Society of Automotive Engineers has adopted this SAFETY ALERT SYMBOL to pinpoint characteristics that, if NOT carefully followed, can create a safety hazard. When you see this symbol in this manual or on the machine itself, BE ALERT! Your personal safety and the safety of others is involved.

Defined below are the SAFETY ALERT messages and how they will appear in this manual:



DANGER

(RED)

Information that, if not carefully followed, can cause death!



WARNING

(ORANGE)

Information that, if not carefully followed, can cause serious personal injury or death!



CAUTION

(YELLOW)

Information that, if not carefully followed, can cause minor injury or damage to equipment.

General Information



CONGRATULATIONS!

The spreader you have purchased is an example of snow and ice control technology at its finest! Your spreader's self-contained design is a trademark of all Snowex products. Here's why...

SIMPLICITY: Fewer moving parts manufactured of higher quality means minimal maintenance for your SnowEx spreader.

RELIABILITY: High impact linear low density polyethylene hopper, state-of-the-art electronic dual variable speed control, custom engineered powder coated frame, maximum torque 12 volt motor coupled to a custom engineered transmission found only on SnowEx products.

VERSATILITY: Multi-use capabilities allows spreading of a variety of materials for snow and ice control.

WARRANTY: Best in the industry, hands down! 2 years standard and now 5 year extended (optional).

The benefits you are about to recognize are that of time, money and effort. We welcome you to the world of Snowex Performance.

Registration

Record the following information in this manual for quick reference.

Spreader Model Number _____

Spreader Serial Number _____ Controller Serial Number _____

Date of Purchase _____

Dealer Where Purchased _____

When ordering parts, the above information is necessary. This will help to insure that you receive the correct parts.

At the right is a diagram of the ID tag. This tag on the spreader is located on the frame.

Please fill out the warranty card with all the necessary information to validate it. This will also give us a record so that any safety or service information can be communicated to you.





Before attempting any procedure in this book, these safety instructions must be read and understood by all workers who have any part in the preparation or use of this equipment.

For your safety, warning and information decals have been placed on this product to remind the operator of safety precautions. If anything happens to mark or destroy the decals, please request new ones from Snowex.



Remember, most accidents are preventable and caused by human error. Exercising of care and precautions must be observed to prevent the possibility of injury to operator or others!



Never operate equipment when under the influence of alcohol, drugs, or medication that might alter your judgment and/or reaction time.



Before working with the spreader, secure all loose fitting clothing and unrestrained hair.



Always wear safety glasses with side shields when working metal against metal. Failure to do this could result in serious injury to the eyes.



Never allow children to operate or climb on equipment.
 Never weld or grind on equipment without having a fire extinguisher available.
 Always check areas to be spread to be sure no hazardous conditions or substances are in the area.
 Always inspect unit for defects: broken, worn or bent parts, weakened areas on spreader or mount.



Always shut off vehicle and power source before attempting to attach or detach or service spreader unit. Be sure vehicle/power source is properly braked or chocked.



Always make sure personnel are clear of areas of danger when using equipment.



Always keep hands, feet, and clothing away from power-driven parts.



Remember, it is the owner's responsibility to communicate information on safe usage and proper maintenance of all equipment.

! WARNING

Never exceed 45 m.p.h. when loaded spreader is attached to vehicle. Braking distances may be increased and handling characteristics may be impaired at speeds above 45 m.p.h.

! CAUTION

Never use wet materials, or materials with foreign debris with any of these spreaders. These units are designed to handle dry, clean, free-flowing material. Note: Can not spread water softener salt.

! CAUTION

Never leave material in hopper for long periods of time. Be aware that all ice melters are hygroscopic and will attract atmospheric moisture and harden up.

! WARNING

Always inspect pins and latches whenever attaching or detaching spreader, and before traveling.

! WARNING

Inspect the unit periodically for defects. Parts that are broken, missing, or worn out must be replaced immediately. The unit or any part of it can not be altered without prior written permission from the manufacturer.

Examples of warning decals to indicate operational awareness.



1 D 6546



2 D 6547



3 D 6545

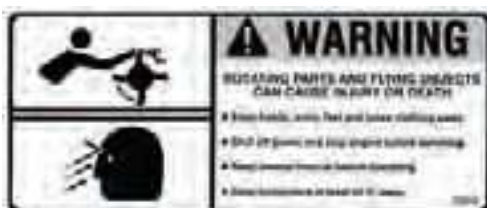

4 D 6544



5 D 6335

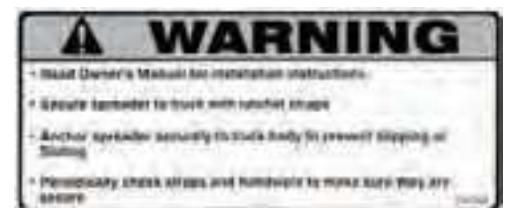

6 D 6548

Parts Breakdown

Model #SP-125 / US-100

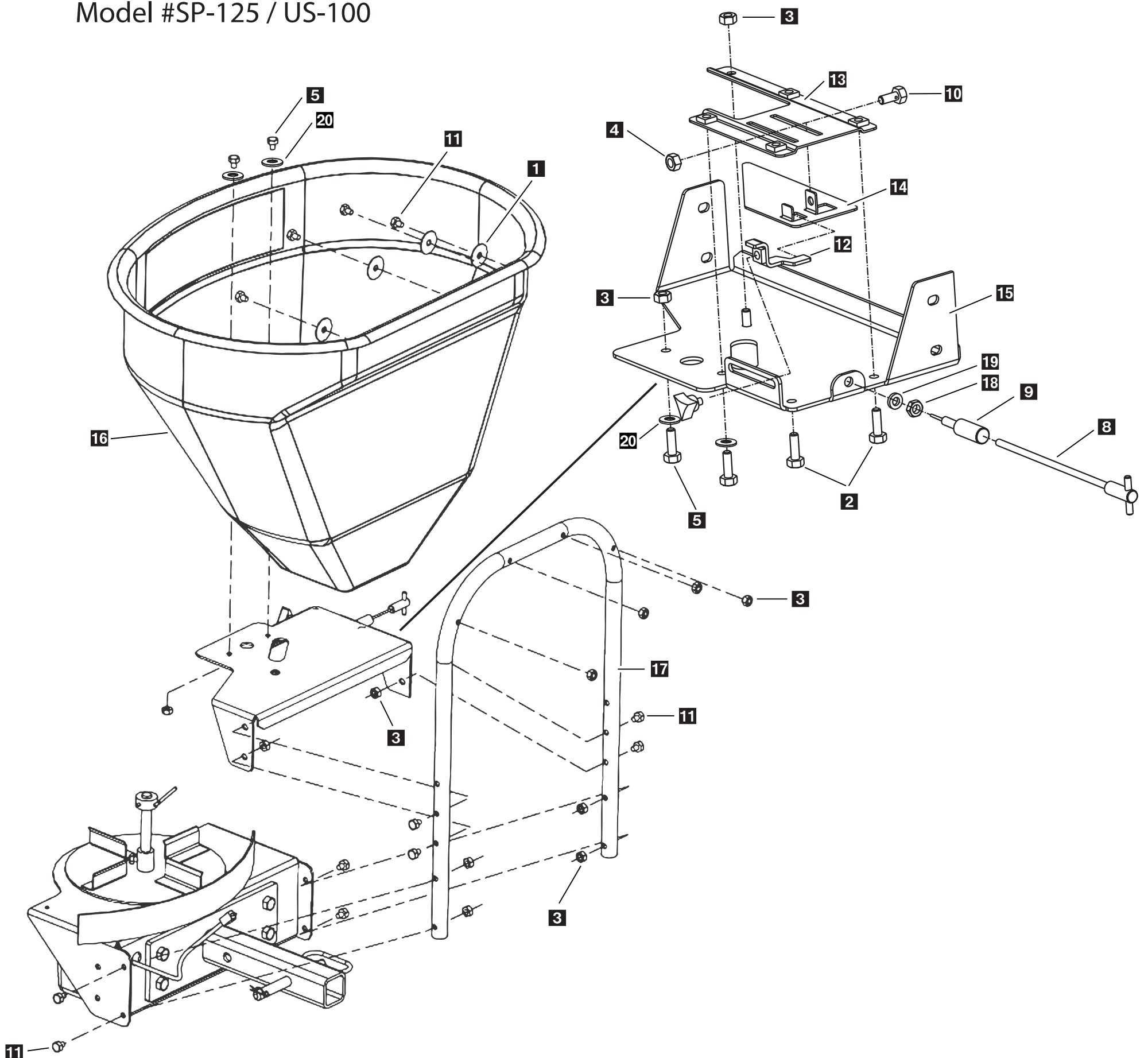

Key	Part No.	Description	Qty.	Key	Part No.	Description	Qty.
1	D4318	WASHER, 3/8 X 1-1/2"	4	11	D6462	BOLT, 5/16-18 X 1-3/4"	12
2	D6133	BOLT, 5/16-18 X 1/2"	2	12	D6703	GATE STOP INDICATOR	1
3	D6138	NUT, 5/16-18	14	13	D6704	GATE TRACK	1
4	T15018	NUT, 5/16-18 NYLOX WAXED	1	14	D6705	GATE SLIDE	1
5	D6166	BOLT, 5/16-18 X 1"	2	15	D6706	GATE DECK	1
6	D6705	GATE SLIDE	1	16	D6753	HOPPER, 3.0 CU. FT. FLAT	1
7	D6302	KNOB, 5/16-18 X 3/4"	1	17	D6712	HOPPER SUPPORT TUBE	1
8	D6304	CABLE, T-HANDLE 10'	1	18	D7172	NUT, 3/8-24 HEX JAM	1
9	D6305	BULKHEAD CABLE FITTING	1	19	D7173	LOCK WASHER, 3/8 INTERNAL	1
10	D6308	BOLT, 5/16-18 X 3/4" HEX HEAD, W/ HOLE	1	20	D6165	WASHER, 5/16	2

Assembly Instructions



Model #SP-125 / US-100 (refer to diagram on page GR4-7)

Step 1: Attach hopper tube support (D 6712) **17** to complete drive assembly using (4) 5/16"-18 x 1-3/4" hex bolt (D 6462) **11** and (4) 5/16" lock nut (D 6138). **3** Use holes at bottom end of tube.

Step 2: Place spreader gate deck (D 6706) **15** upside down on table.

Step 3: Assemble gate indicator/stop (D 6703) **12** on stop slide with gate knob (D6302). **7** Gate stop must be on the inside of deck where it will stop the track.

Step 4: Insert (1) 5/16 bolt with hole (D 6308) **10** through gate slide (D 6705) **12** Finger tighten (1) 5/16" locknut (D 6138) (D 6308) **3** on bolt

Step 5: Take bulkhead cable fitting (D 6505) **9** and screw it onto T-handle cable - 10' (D 6304) **8** rubber coating.

Step 6: Place assembly through tab on gate deck. Tighten down with supplied washer and nuts. Note: There should be a nut on either side of tab.

Step 7: Lower gate assembly over spinner shaft. Spinner shaft must go through 5/8" hole on deck.

Step 8: Fasten deck to hopper tube using (4) 5/16" hex bolts (D 6462) **11** and (4) 5/16" locknuts (D 6138) **3** NOTE: You must first tighten bottom bolts, pull front of deck up, then tighten top set of bolts.

Step 9: Place hopper (D 6753) **16** on deck. 5/8" hole must be used for spinner shaft.

Step 10: Finger tighten (2) 5/16 x 1" bolts (D 6166) **5** through bottom of hopper.

Step 11: Place (4) flat washers (D 4318) **1** over hex bolts (D6462). Place bolts through hopper back and in though tube support. Tighten with (4) 5/16" locknuts.

Step 12: Tighten bolts in bottom of hopper.

Step 13: Place agitator (D 6405) on spinner shaft. Tighen to middle of flat with short allen key.

Step 14: Attach receiver mount (D 6485) to transmission weldment (D 6480) using (4) 1/2" hex bolts (D 4116) and (4) 1/2" lock nuts (D 4120).

Gate Cable Installation

Step 1: Place unit on vehicle where it will be permanently used. Place hitch pin in hitch so unit does not move.

Step 2: Route T-handle to desired operating location. There cannot be any bends or sharp corners.

Step 3: Take T-handle out of sleeve. Take nuts and washer off of sleeve.

Step 4: Drill hole to mount T-handle. Screw (1) supplied nut and washer on cable after inserting through drilled hole.

Step 5: Close gate slide all the way.

Step 6: Re-insert cable handle and wire all the way. Aim through bolt with hole and tighten bolt.

Complete Drive Assembly Parts Breakdown

Model #SP-125/US-100

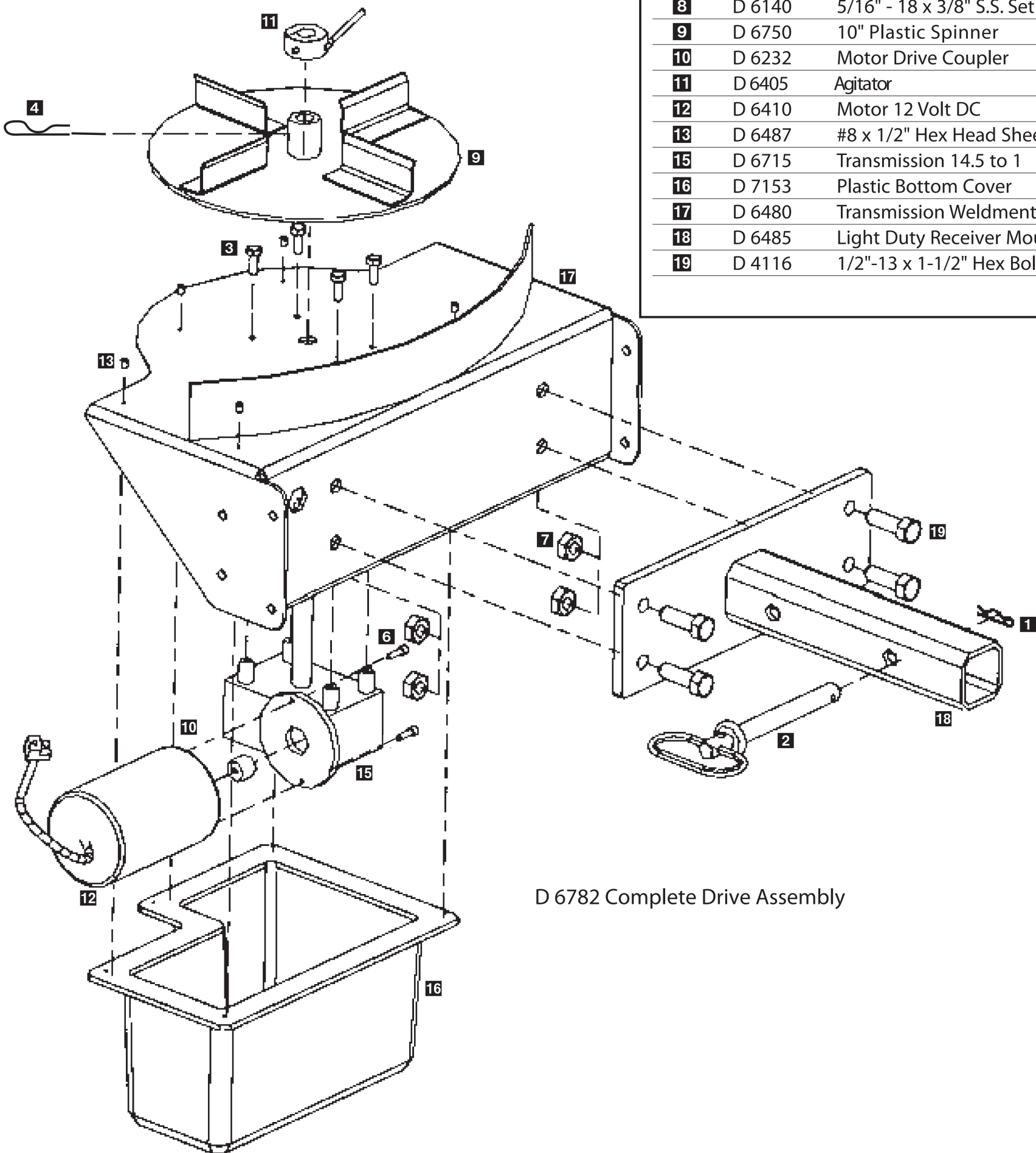

Key	Part No.	Description	Qty.
1	D 4135	2-5/16" Hair Pin Clip	1
2	D 4136	5/8" x 5-1/2" Hitch Pin	1
3	D 6131	1/4"-20 x 1/2" Serr. Flange Bolt	4
4	D 6746	5/16" x 1-1/4 Detent Clevis	1
6	D 6172	#10-32 x 5/8" Serr Flange Bolt	2
7	D 4120	1/2" Lock Nut	4
8	D 6140	5/16" - 18 x 3/8" S.S. Set Screw	1
9	D 6750	10" Plastic Spinner	1
10	D 6232	Motor Drive Coupler	1
11	D 6405	Agitator	1
12	D 6410	Motor 12 Volt DC	1
13	D 6487	#8 x 1/2" Hex Head Sheet Screw	5
15	D 6715	Transmission 14.5 to 1	1
16	D 7153	Plastic Bottom Cover	1
17	D 6480	Transmission Weldment	1
18	D 6485	Light Duty Receiver Mount	1
19	D 4116	1/2"-13 x 1-1/2" Hex Bolt	4

D 6782 Complete Drive Assembly

Parts Breakdown

Model #SP-225 / US-200

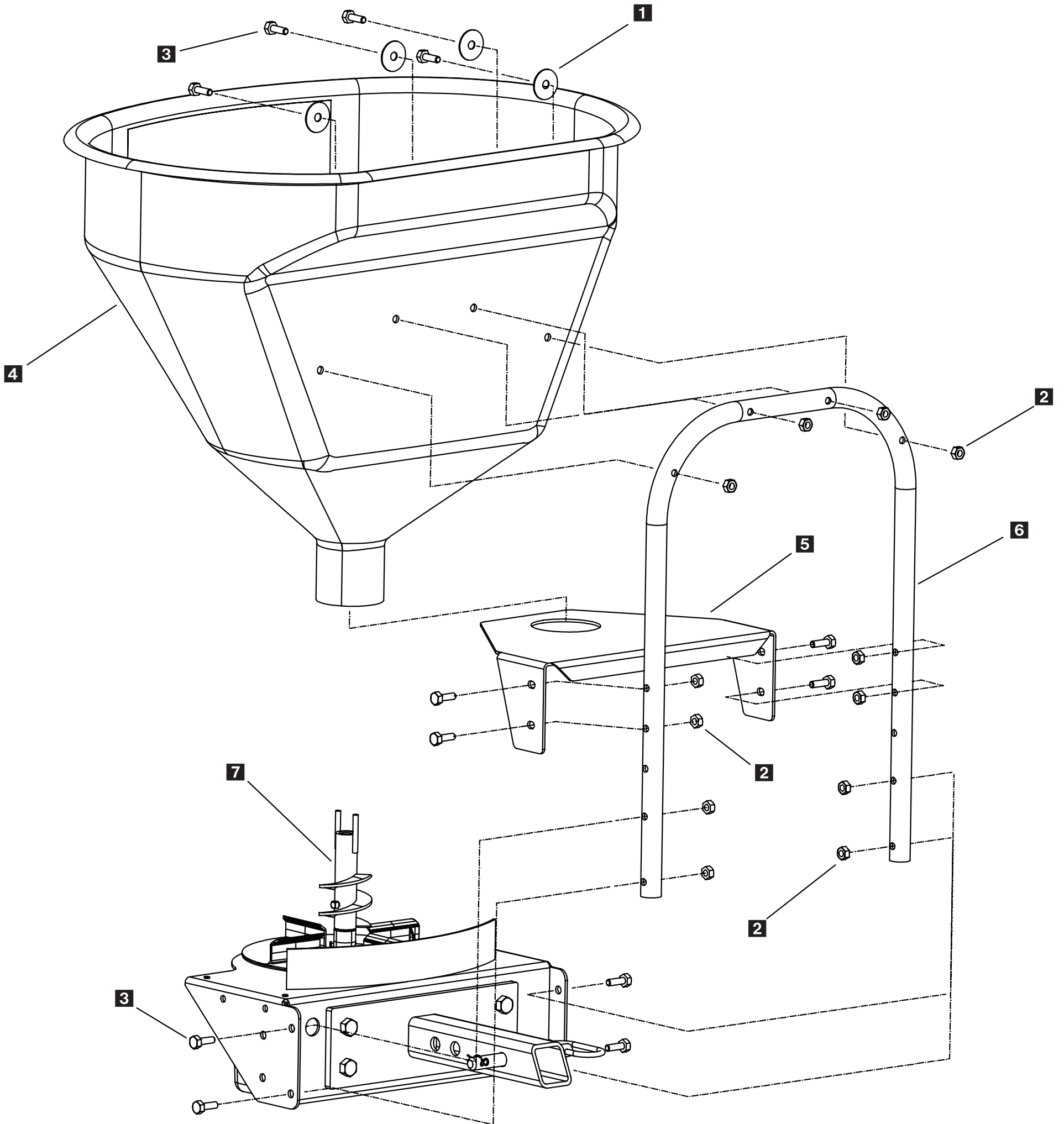

Key	Part No.	Description	Qty.
1	D 4318	3/8" Fender Washer	4
2	D 6138	5/16" Locknut	12
3	D 6462	5/16" - 18 x 1-3/4" HHCS	12
4	D 6754	2.7 cu/ft Salter Hopper Yellow	1
5	D 6702	Salter Throat Deck	1
6	D 6712	Hopper Tube Support	1
7	D 6783	Complete Drive Assembly	1

Assembly Instructions



Model #SP-225 / US-200 (refer to diagram on page GR4-10)

Step 1: Attach hopper tube support (D 6712) **6** to complete drive assembly using (4) 5/16"-18 x 1-3/4" hex bolt (D6462) **3** and (4) 5/16" locknut (D6138) **2**. Use holes at bottom end of tube.

Step 2: Take auger (D 6122) and set on table to tap (1) cap (D 6191) into tube between auger uprights.

Step 3: Place auger on shaft of transmission and tighten to top of flat with (1) set screw (D 6140).

Step 4: Place salter throat deck (D 6702) **5** over auger and between hopper tubing support.

Step 5: Using (4) 5/16"-18 x 1-3/4" bolts (D 6462) **3** and (4) 5/16" locknuts (D 6138) **2**, hand tighten through upper set of holes on tube support.

Step 6: With 1/2" wrench and socket, tighten bottom set of bolts on throat deck **5**

Step 7: Lift up on throat deck at the front (auger hole side) to level deck. Tighten top set of bolts.

Step 8: Place hopper throat (D 6754) **4** through deck around auger. Line up with holes in tube support.

Step 9: Place 3/8" fender washer (D 4318) **1** on (4) 5/16" hex bolts (D 6462) **3**. Insert through hopper, through tube and secure with 5/16" nut on back of unit. Tighten.

Step 14: Attach receiver mount (D 6485) to transmission weldment (D 6480) using (4) 1/2" hex bolts (D 4116) and (4) 1/2" lock nuts.

Step 8: Insert receiver tube end into Receiver Hitch and secure with pin (D 4136).

Step 9: Wire spreader according to wiring instructions.

Complete Drive Assembly Parts Breakdown

Model #SP-225 / US-200

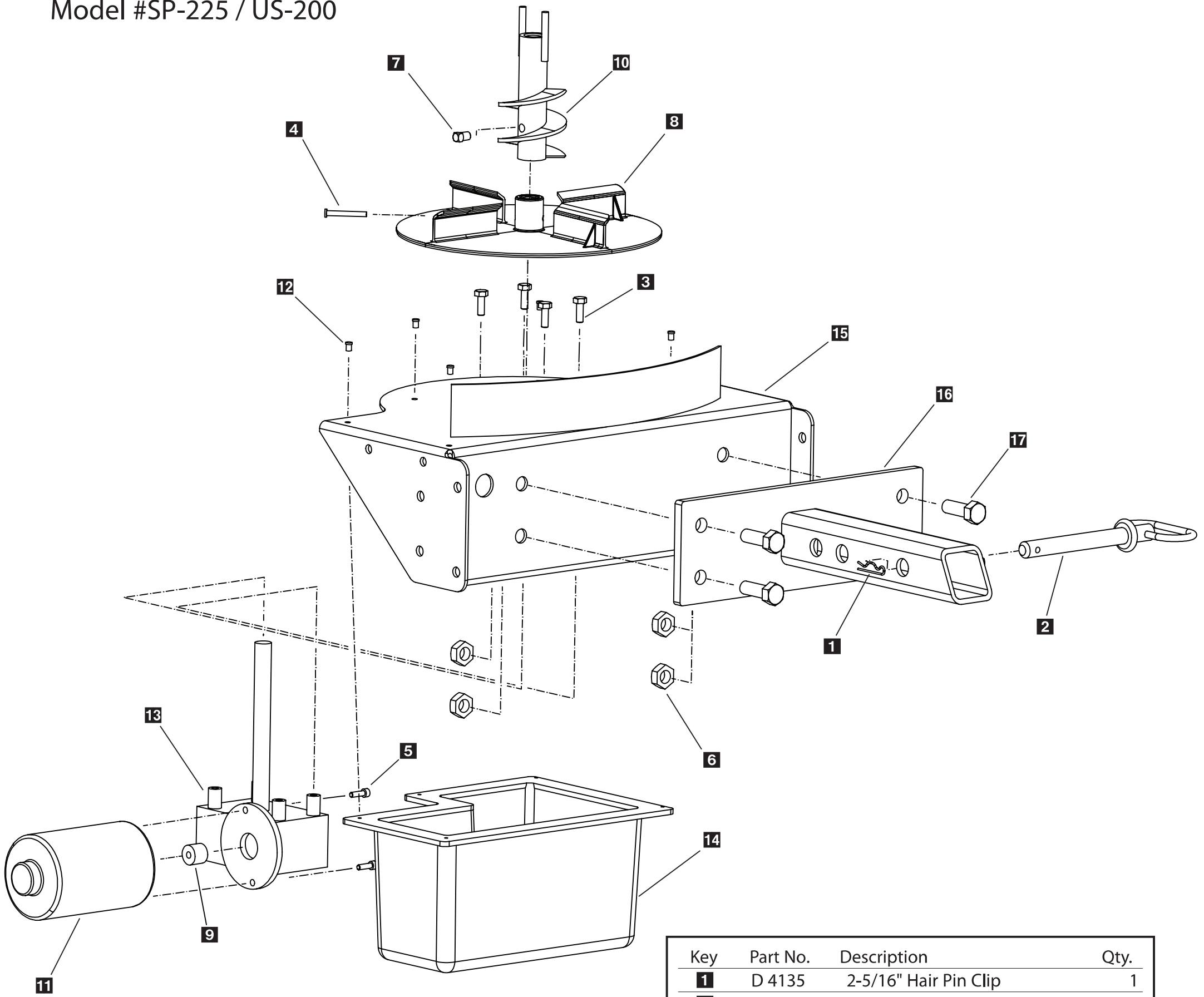

Complete Drive Assembly
D 6783

Key	Part No.	Description	Qty.
1	D 4135	2-5/16" Hair Pin Clip	1
2	D 4136	5/8" x 5-1/2" Hitch Pin	1
3	D 6131	1/4"-20 x 1/2" Serr Flange Bolt	4
4	D 6746	5/16" x 1/4" Detent Clevis Pin	1
5	D 6172	#10-32 x 5/8" Serr Flange Bolt	2
6	D 4120	1/2" Lock Nut	4
7	D 6140	5/16" - 18 x 3/8" S.S. Set Screw	1
8	D 6750	10" Plastic Spinner	1
9	D 6232	Motor Drive Coupler	1
10	D 6122	Auger	1
11	D 6410	Motor 12 Volt DC	1
12	D 6487	#8 x 1/2" Hex Head Sheet Screw	5
13	D 6715	Transmission 14.5 to 1	1
14	D 7153	Plastic Bottom Cover	1
15	D 6480	Transmission Weldment	1
16	D 6485	Light Duty Receiver Mount	1
17	D 4116	1/2"-13 x 1-1/2" Hex Bolt	4

Wiring Diagram

Model #SP-125/SP-225/US-100/US-200

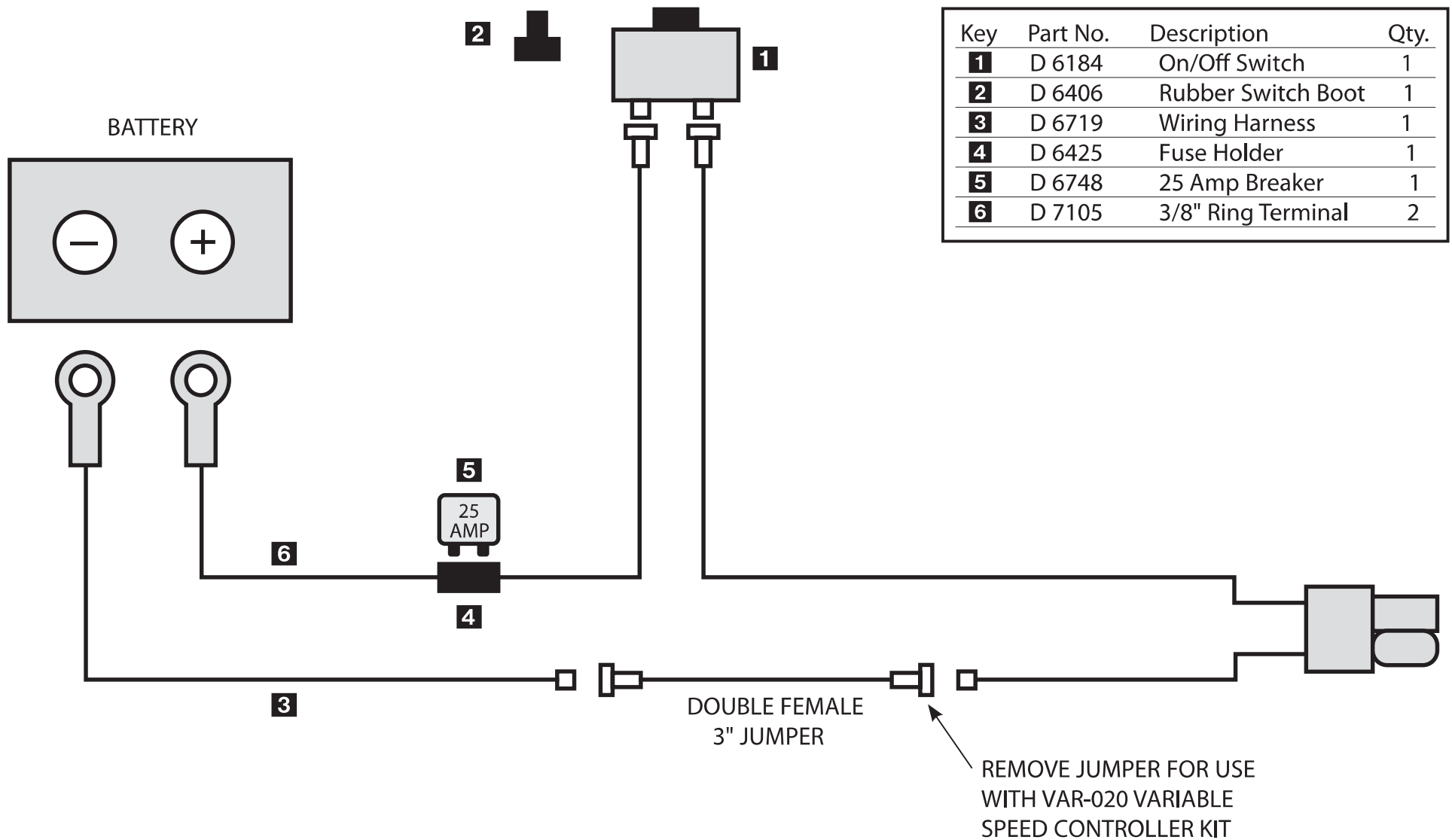

IMPORTANT: In the off season remove control and put in a cool dry place. The interior summer temperatures could damage circuit board and void warranty.

SP-125 / SP-225 / US-100/ US-200 Wiring Instructions

Step 1: First, install switch at desired location.

Step 2: Run spreader/vehicle harness from the rear of vehicle to switch area. Attach the female spade red wire to the switch. Leave the black wire for Step 5.

Step 3: Route the power harness from the battery to the switch/control.

Step 4: Attach the red lead to the positive side of the battery and the black lead to the negative side of the battery.

Step 5: Attach the female spade red wire on switch terminal. Using 3" double female black wire jumper attach the black wire from the power harness to the black wire of the vehicle harness.

Step 6: Install rubber weatherproof boot on switch before finishing installation.

Step 7: Insert dielectric grease on terminals of SAE plug at rear of vehicle.

Variable Speed Control (Optional Kit)

Model # VAR-020

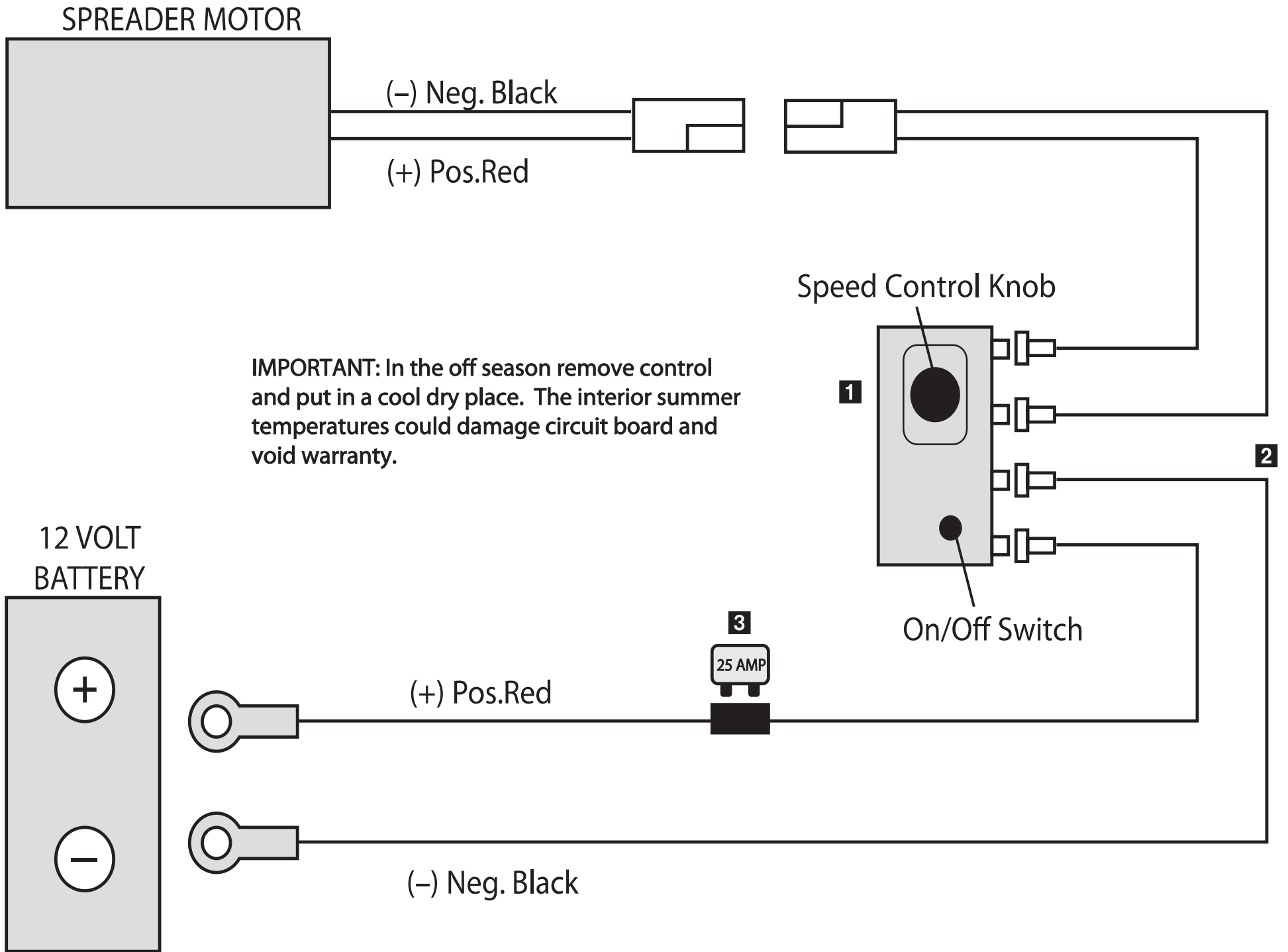

Key	Part No.	Description	Qty.
1	D 6474	Mini Control	1
2	D 6486	325 Harness	1
3	D 6748	25 Amp Breaker	1

Utility Mount Parts Breakdown

Model #UTM-175 / FLM-175

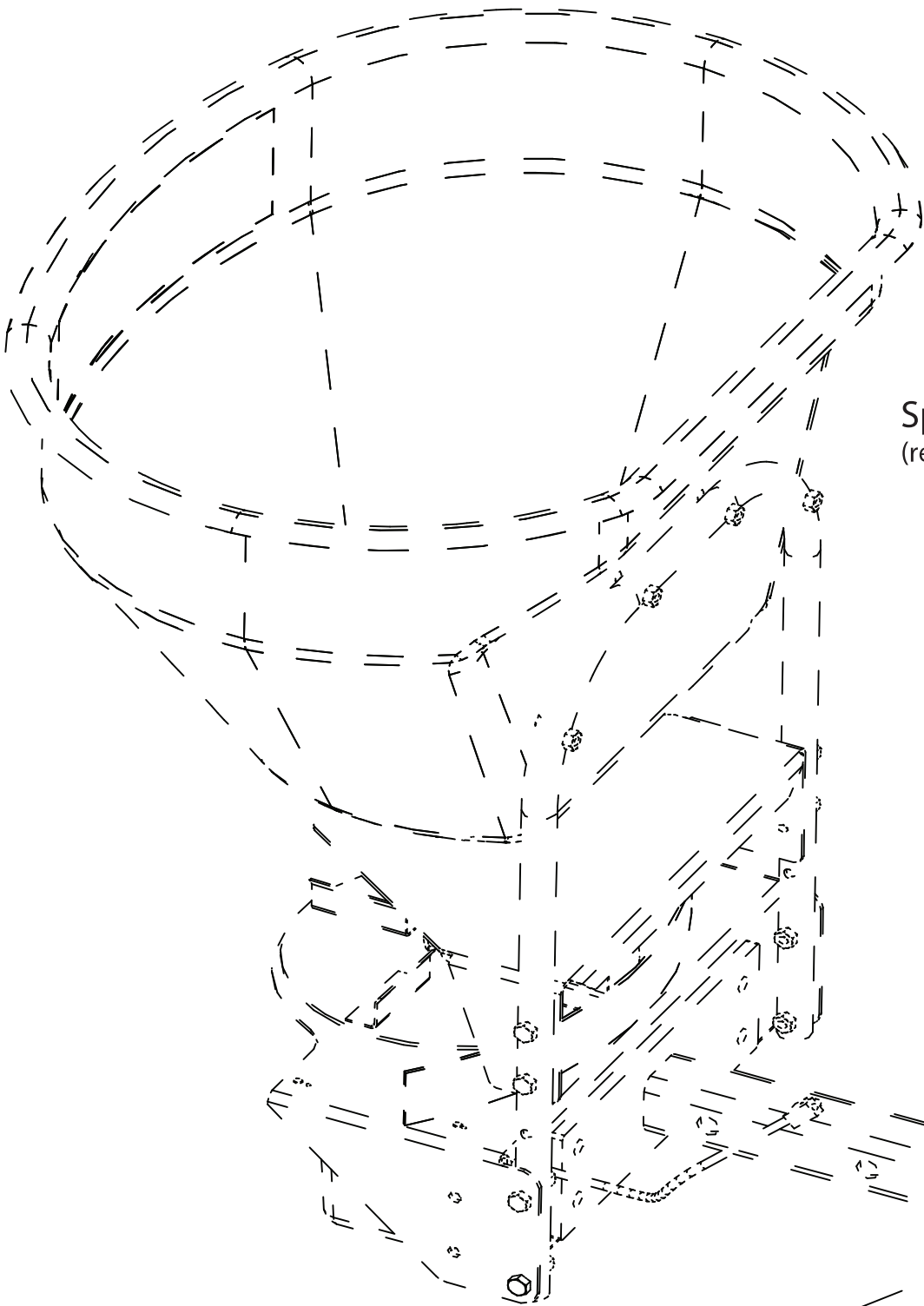

Spreader
(reference only)

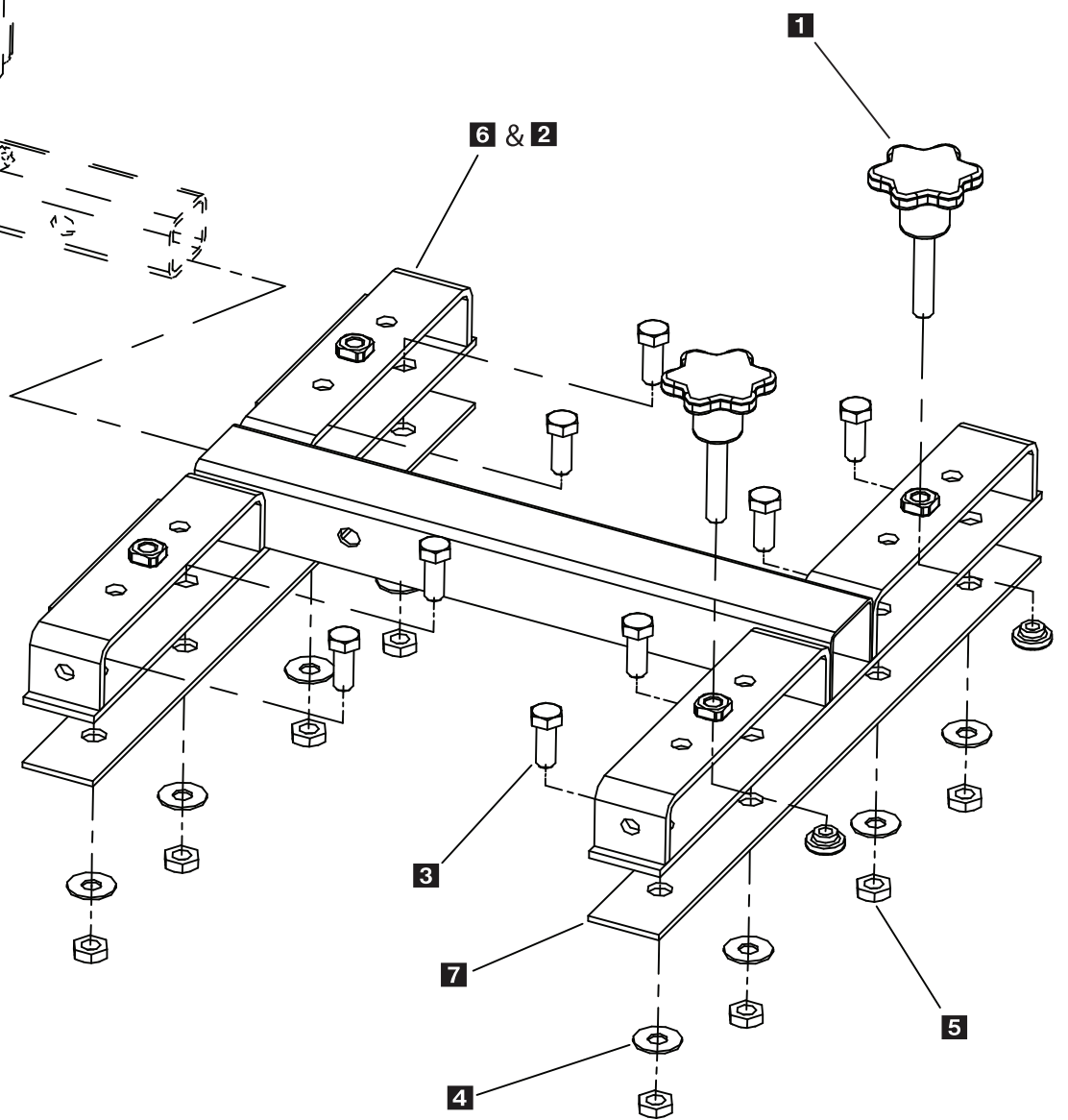

Maximum Load Weight
Not To Exceed 240 lbs. Gross

Key	Part No.	Description	Qty.
1	D 4315	Lock Knob Assembly (FLM-175 Only)	2
2	D 6426	Fork Lift Mount Frame (FLM)	1
3	D 4116	1/2"-13 x 1 1/2" Hex Bolt	8
4	D 4119	1/2" Flat Washer	8
5	D 4120	1/2" Lock Nut	8
6	D 6148	Utility Receiver (UTM)	1
7	D 6235	Underbody Support Plate	2

Trailer Mount Parts Breakdown

Model #TLR-175



MAXIMUM LOAD WEIGHT NOT TO EXCEED 240 LBS. GROSS

TRAILER MOUNT ASSEMBLY INSTRUCTIONS

Step 1: Insert axle through wheel and axle weldment.

Step 2: Put washer on, then install hair pin clip to secure axle. Repeat Steps 1 and 2 for other side.

Step 3: Bolt tube support on axle weldment.

Step 4: Insert trailer tongue per drawing and pin into position.

Step 5: Insert spreader mount into opposite side of trailer tongue and pin into position.

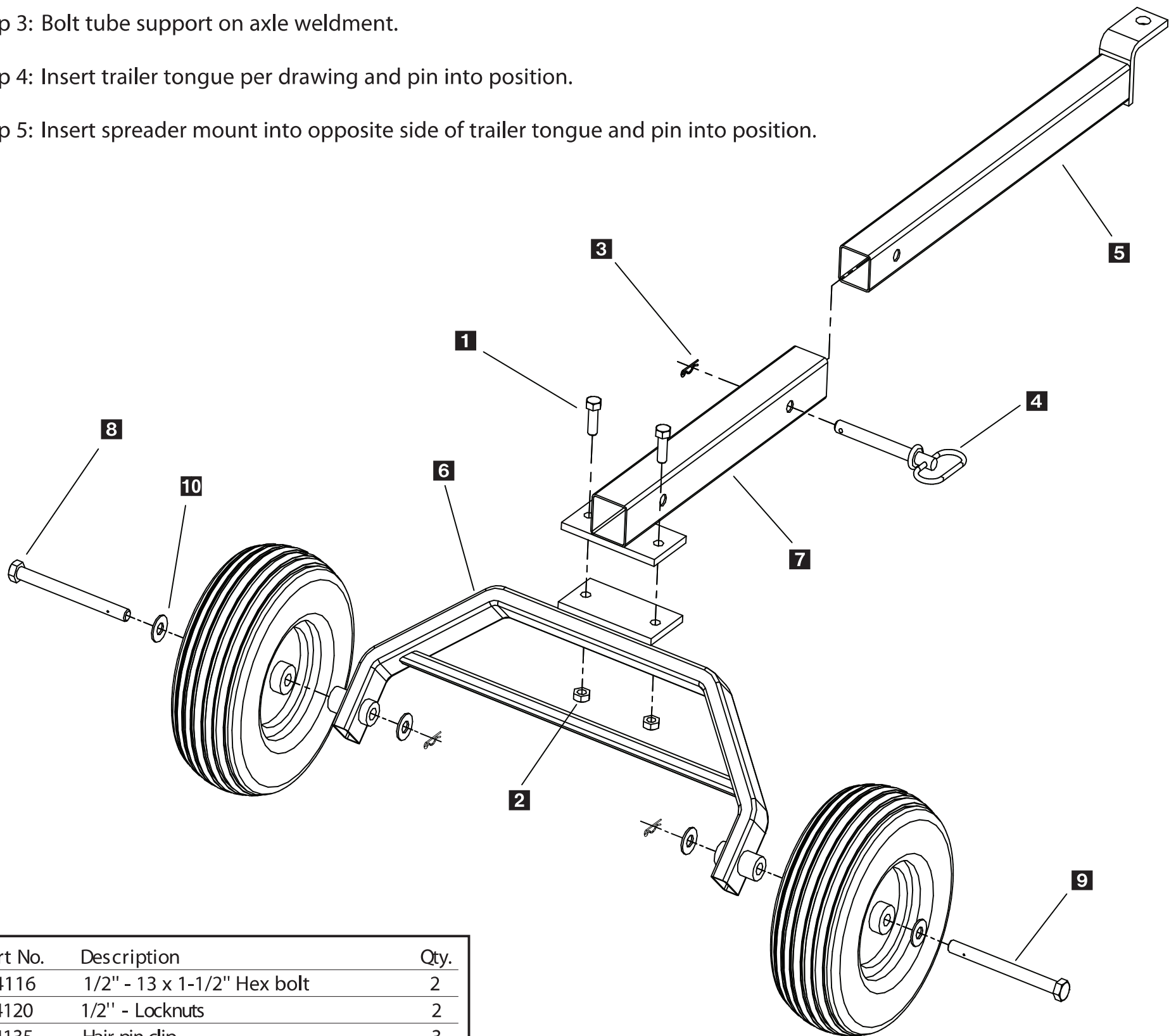

Key	Part No.	Description	Qty.
1	D 4116	1/2" - 13 x 1-1/2" Hex bolt	2
2	D 4120	1/2" - Locknuts	2
3	D 4135	Hair pin clip	3
4	D 4136	5/8" x 5 -1/2" Hitch pin	1
5	D 6438	Trailer tongue	1
6	D 6439	Trailer "A" frame	1
7	D 6440	Receiver tube mount	1
8	D 6441	Trailer tire	2
9	D 6442	5/8" - 13 x 7" Hex bolt special	2
10	D 6443	5/8" Flat washers	4

Three-Point Mount Parts Breakdown

Model #TPM-175

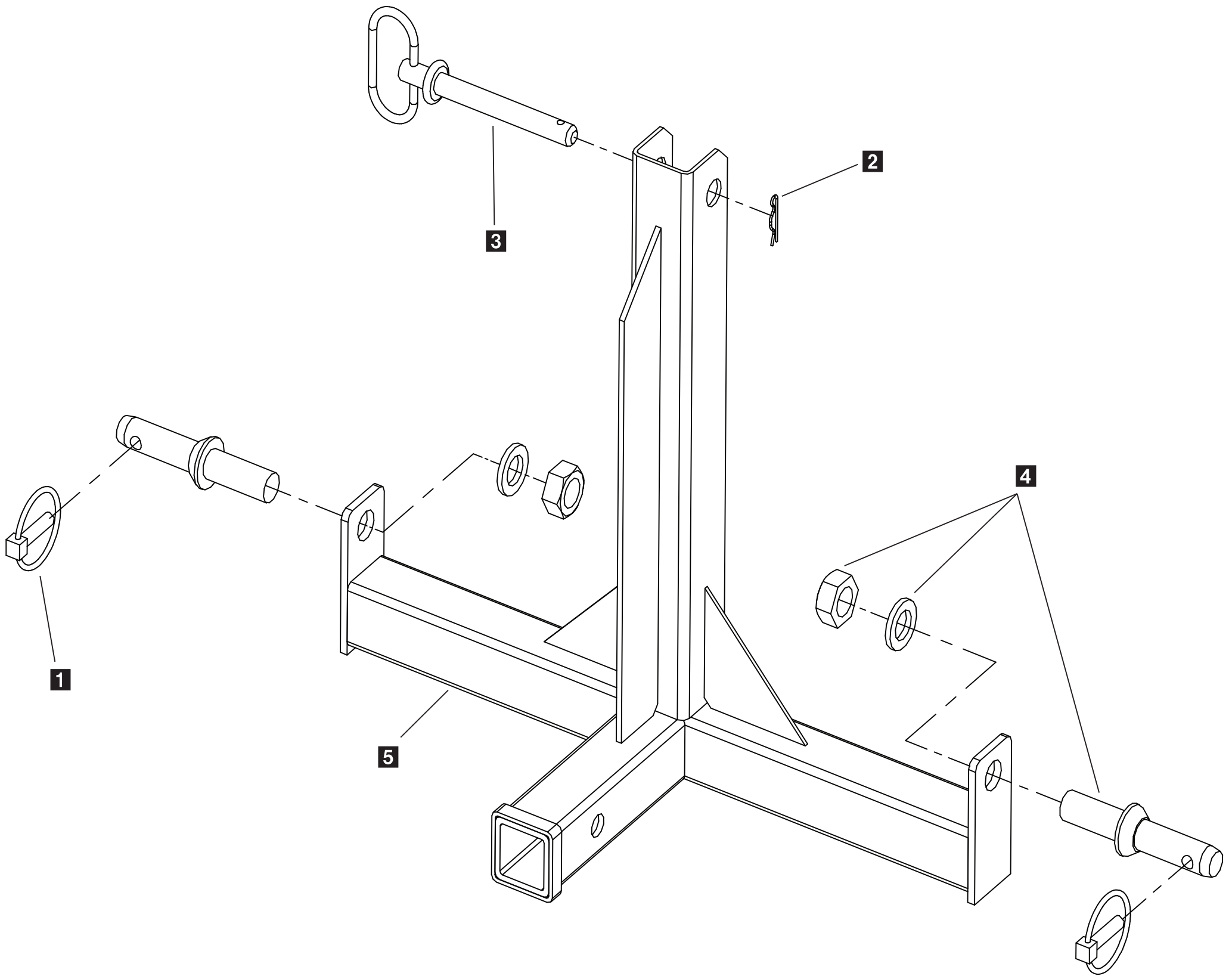

Key	Part No.	Description	Qty.
1	D 4133	5/16" Lynch Pin	2
2	D 4135	2-5/16" Hairpin Clip	1
3	D 4136	5/8" x 5-1/2" Hitch Pin	1
4	D 4137	7/8" x 5-1/2" Lift Arm Pin	2
5	D 6147	Three Point Frame	1

CAUTION: MAXIMUM OF 240 LBS. GROSS WEIGHT CAN BE PUT ONTO MOUNT.

Pivot Pal Mount Parts Breakdown

Model #PPT-175

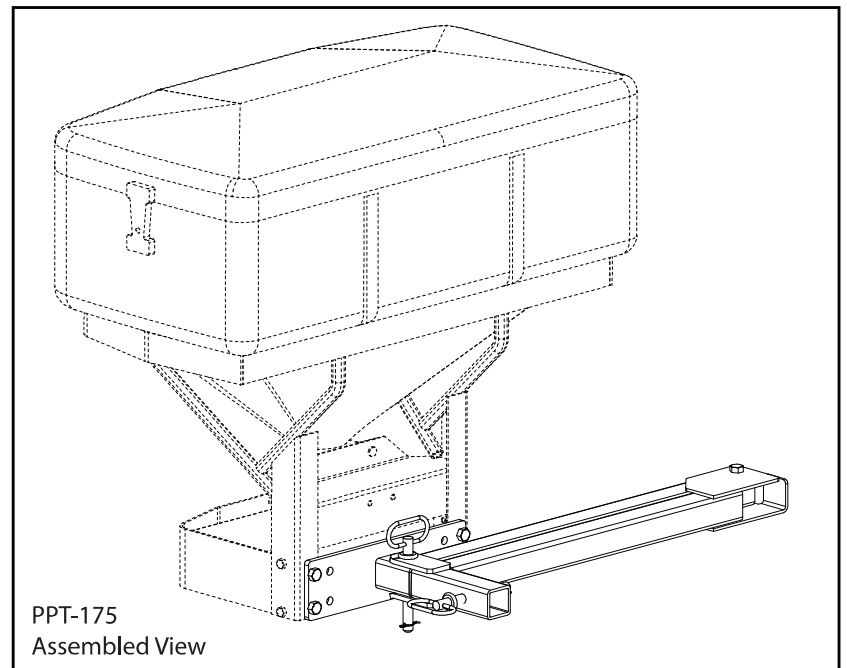
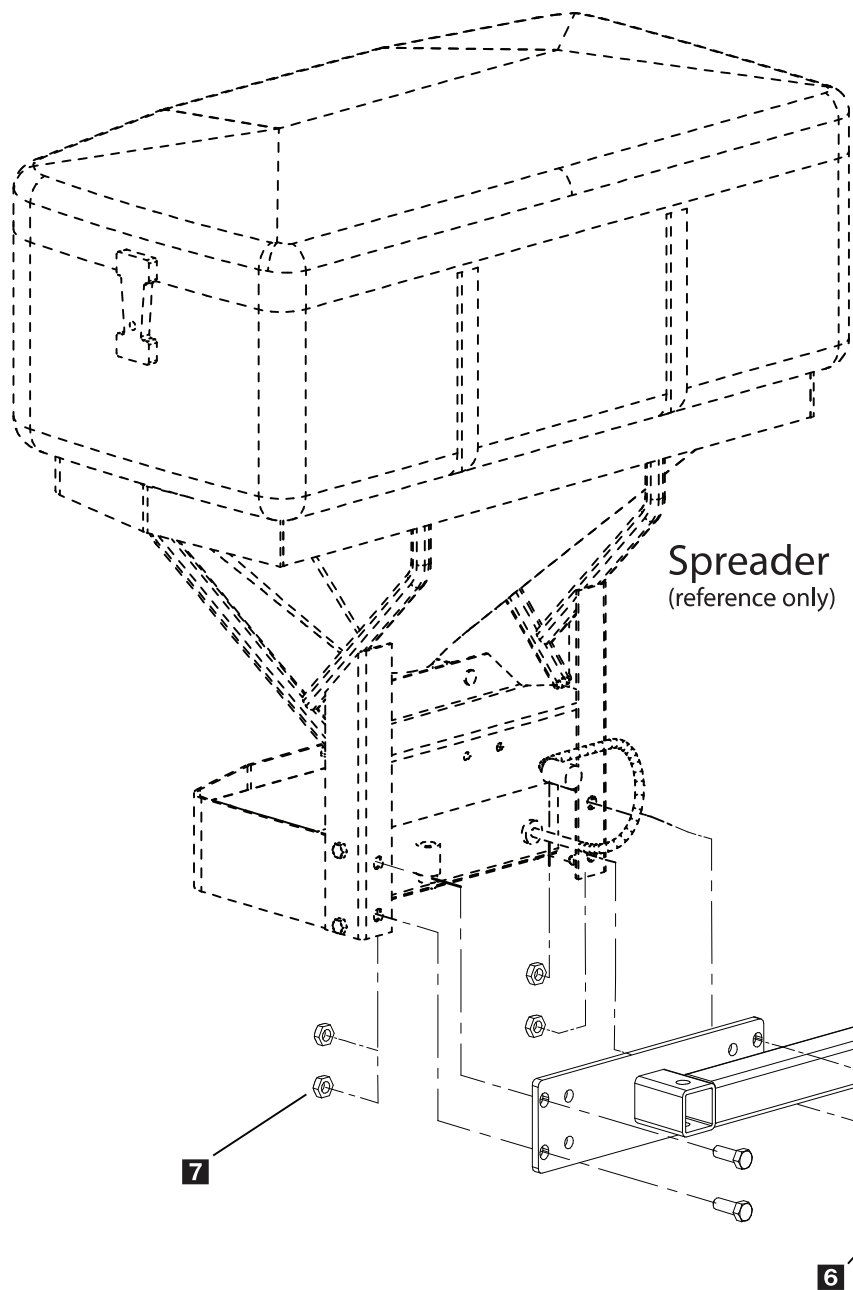

Step 1: Assemble spreader swing arm **2** to spreader hitch arm **1** with **8** and **4** & **5** nut and bolt. Do not over tighten since this may cause the arm to bind and will not swing open freely.

Step 2: Collapse assembly and install **3** hitch pin to keep assembly from opening.

Step 3: Remove existing 1/2" bolts from spreader drive assembly and mount spreader assembly to spreader (see illustration). Re-tighten hardware per illustration.

Step 4: With assistance, lift spreader into position and insert into vehicle receiver mount. Install **3** hitch pin with clip.

Step 5: Remove swing arm hitch pin and swing spreader out on drivers side, at this time use a spray lubricant such as automotive lithium type or a grease based product. This will help prevent unwanted corrosion in the pivot joint; this should be checked on a regular basis during the season.

Step 6: Close spreader and re-install hitch pin with clip.

Step 7: Plug spreader into spreader harness and test for power on.

Key	Part No.	Description	Qty.
1	D 6051	Hitch Arm	1
2	D 6052	Swing Arm	1
3	D 4136	Hitch Pin With Clip	2
4	D 6052	1/2" x 2-1/2" Shoulder Bolt	1
5	D 4124	3/8"-16 Nylon Hex Nut	1
6	D 4116	1/2"-13 x 1-1/2" Hex Bolt	4
7	D 4120	1/2"-13 Lock Nut	4
8	D 6049	1/2" x 1/6" Bronze Thrust Washer	2

Drop Utility Mount Parts Breakdown

Model #DRM-175

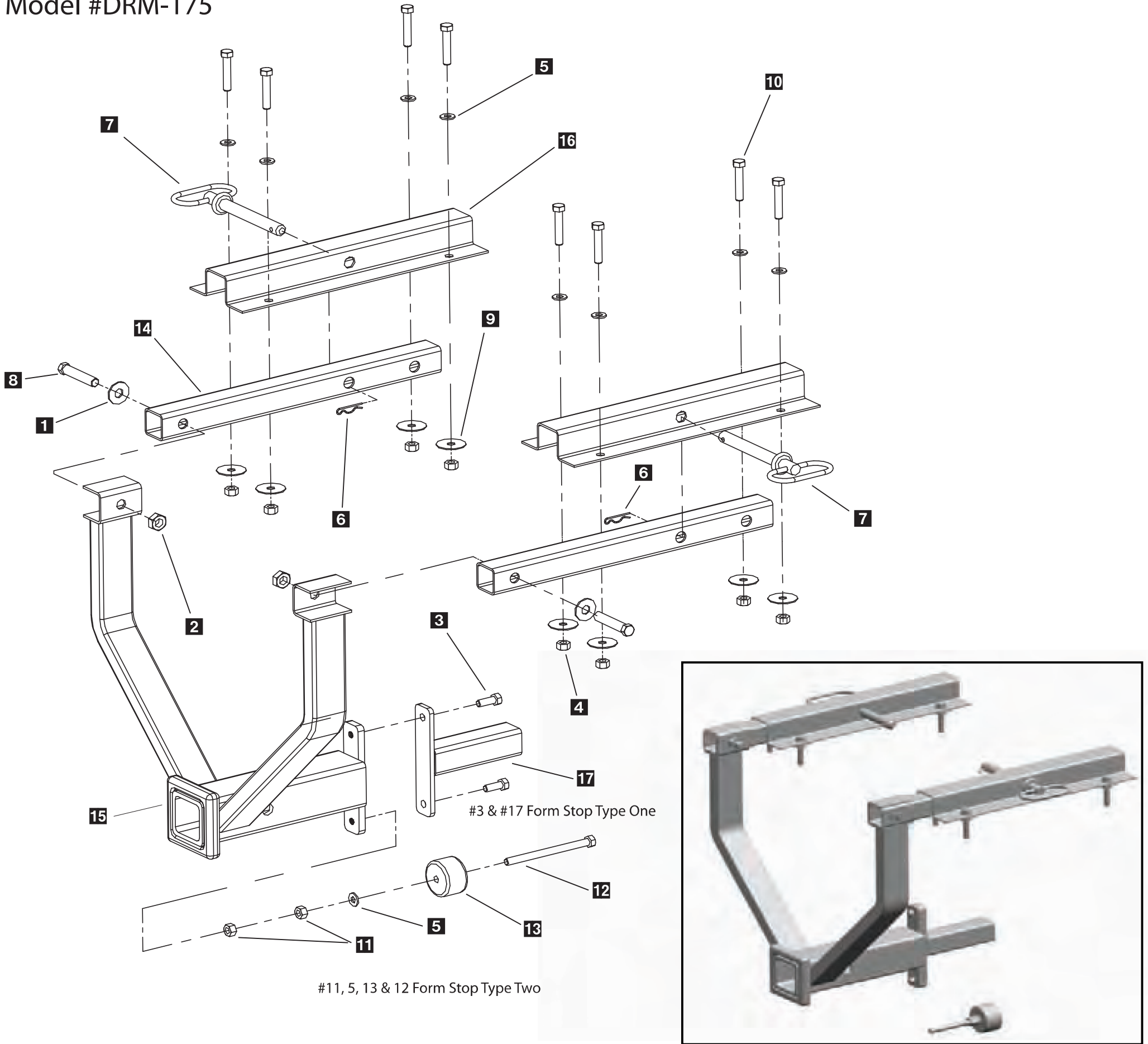

Maximum Load Weight Not To Exceed 240 lbs. Gross

Key	Part No.	Description	Qty.	Key	Part No.	Description	Qty.
1	D 4119	1/2" Flat Washer	2	10	D 6420	3/8" - 16 x 2 Truss Bolt Full Thread	8
2	D 4120	1/2"-Lock Nut	2	11	D 6421	3/8" - 16 Hex Nut	2
3	D 4121	3/8"-16x1 Hex Bolt	2	12	D 6422	3/8" - 16 x 5" Hex Bolt	1
4	D 4124	3/8"-Lock Nut	8	13	D 6423	2" Rubber Stopper	1
5	D 4125	3/8" Flat Washer	9	14	D 6432	Mounting Rail	2
6	D 4135	2 - 5/16" Hair Pin Clip	2	15	D 6434	Drop Mount Weldment	1
7	D 4136	5/8" x 5-1/2" Hitch Pin	2	16	D 6435	Mounting Rail Hat Section	2
8	D 6246	1/2" - 13 x 2-1/2" Hex Bolt	2	17	D 6436	Mule Adapter	1
9	D 4318	3/8" Fender Washer	8				

Drop Utility Mount Installation Instructions

Model # DRM-175

MULE 550

Step 1: Temporarily remove the tailgate. Remove the bed liner if equipped.

Step 2: Bolt support rails to spreader mount with 1/2" bolts. Install 1/2" hex bolt with washer through rail first then spreader mount. Install 1/2" locknut and tighten. Avoid over tightening to avoid potentially crushing tube.

Step 3: Place spreader mounting rails over spreader mount support rails and install pins. Locate the spreader bracket mounting rails on top of the bed by centering left to right and positioning the rear edge of the rails 5/8" beyond the rear of the bed. Transfer mounting holes to bed and drill 7/16" holes.

Important: Check for proper clearance underneath bed before drilling holes.

Step 4: Bolt rails under belt with truss head bolts, fender washers, SAE washers and nylock nuts. Install the spreader bracket before tightening hardware. The tailgate and bed liner may be reinstalled now.

Step 5: Install 550 anti dump bracket with (2) 3/8" bolts provided.

Step 6: Install gate control cable per attached instructions.

Step 7: Route Cables at your discretion and install switch.

MULE 2500

The installation of the spreader on the 2500 is the same as the 550 with the following exceptions.

Step 1: When positioning the mounting rails, the end of the rail should be 1/2" forward of the rear edge of the bed.

Step 2: The universal anti dump threads into the lower weld nut on the spreader bracket assembly. Adjust rubber bumper to be 1/2" to 3/4" behind the rear axle-receiver hitch assembly.

CLUB CAR CARRYALL

Step 1: Remove the bed tailgate and bottom angle trim. Also remove the two rear carriage bolts from the floor of the bed. Locate the two front outside mounting rails over the holes from the carriage bolts and remove.

Step 2: Place spreader mounting rails over spreader mount and install pins.

Step 3: Install truss head bolts, fender washers, SAE washers and nylock nuts in the carriage bolt holes. Transfer the remaining mounting rail holes and bolt rails into bed.

JOHN DEERE GATOR

Step 1: Remove the bed tailgate.

Step 2: Place spreader mounting rails over spreader mount and install pins.

Step 3: Locate the spreader bracket mounting rails on top of the bed by centering left to right, push main mount flush up against rear of bed to locate mounting rails. Transfer mounting holes to bed.

Step 4: Install truss head bolts, fender washers, SAE washers and nylock nuts in the 1/2" mounting holes.

Step 5: The universal anti dump threads into the lower weld nut on the spreader bracket assembly. The rubber bumper should be adjusted to rest against the frame of the vehicle. The trailer hitch bracket may need to be relocated depending on the configuration.

CAUTION: MAXIMUM WEIGHT NOT TO EXCEED 240 LBS.

PREPARATION

CAUTION –Sweep area clear of foreign objects or obstacles that could cause personal injury. Keep other persons, children, or animals out of the area to be spread.

SPREADER LOADING

WARNING –Do not overload vehicle. Use chart below to calculate weight of material. Weights of material are an average for dry materials.

<u>Material</u>	<u>Weight Per Cubic Ft.</u>
Rock Salt	35-40 lbs.

- Be sure to comply with manufacturer’s maximum gross vehicle weight ratings.
- Warning– Never leave materials in hopper for long periods of time as salt is hygroscopic and will attract atmospheric moisture and harden up.

SPREADING TIPS

- Never exceed 10 m.p.h. when spreading.
- For a wider pass, increase spinner speed.
- Never operate spreader near pedestrians.
- Spread ice melters with the storm to prevent unmanageable levels of ice.
- Calculate spread pattern when near vegetation.

SPREADER OPERATION

SP-125 / US-100 SPREADER

- Comes standard with on/off switch and gate flow control kit.
- To start, switch power on and open gate to desired position.
- To stop, close gate and switch power off.

SP-225 / US-200 SPREADER

- Comes standard with on/off switch.
- To start, switch power on and material will begin to flow via the feed auger.
- To stop, switch power off and material will cease to spread.

THIS PAGE INTENTIONALLY LEFT BLANK

- **WARNING** – When servicing is necessary, perform it in a protected area. Do not use power tools in rain or snow because of danger of electrical shock or injury. Keep area well lighted. Use proper tools. Keep the area of service clean to help avoid accidents.
- **WARNING** – Disconnect electricity to spreader before servicing.
- **CAUTION** – The controller is a solid state electronic unit and is not serviceable. Any attempt to service will void warranty.
- **CAUTION** – There are no serviceable parts in the motor/transmission assembly. Any attempt to service will void warranty.
- **CAUTION** – When replacing parts, use only original manufacturer's parts. Failure to do so will void warranty.
- Use dielectric grease on all electrical connections to prevent corrosion at the beginning and end of the season and each time power plugs are disconnected.
- Wash unit after each use to prevent material build-up and corrosion.
- **CAUTION** – When pressure washing motor enclosure area, stay at least 36" away from motor enclosures.
- Paint or oil all bare metal surfaces at the end of the season.
- If motor cover is removed for any reason, use silicone sealant to ensure weather proofing of enclosure.
- After first use, tighten all nuts and bolts on spreader and mount.
- Apply a small amount of oil on gate cable to prevent corrosion and maximize the cable life (AF-100 Gate Assembly).
- **CAUTION** – Spinner motor is not designed for continuous duty. Allow motor to cool between long cycle times.

Troubleshooting



Model # SP-125 / US-100 / SP-225 / US-200

Whenever service is necessary, your local Snowex Dealer knows your Spreader best. Take your Spreader to your local dealer for any maintenance or service needs on your unit. If this is not possible, the Troubleshooting Guide below may assist you in locating the problem.

Warning: First read all warning instructions and safety messages before servicing your spreader.

Preliminary Checks

- Be sure all electrical connections are tight and clean.
- Be sure nothing is jammed in the hopper.

PROBLEM	POSSIBLE CAUSE	SOLUTION
Motor doesn't run.	Loose electrical connections.	Check all connections.
	Blown Fuse.	Replace fuse.
	Motor Seized.	Replace motor.
Controller shut down.	Jammed auger.	Carefully clear jammed material.
	Poor electrical connections.	Clean or replace connectors. Use dielectric grease.
	Electrical short.	Check electrical connections. Check for bare wires.
	Controller failure.	Replace controller.
Material not flowing from hopper.	Empty hopper.	Fill hopper.
	Wet material.	Replace with dry material.
	Frozen or coarse material.	Replace material.
	Spinner not turning.	Check drive assembly.
	Auger loose on shaft.	Tighten locking bolt on the side of the auger. There is a flat machined on the driver shaft. Align the auger with this flat and tighten the bolt.

Troubleshooting



Model # SP-125 / US-100 / SP-225 / US-200

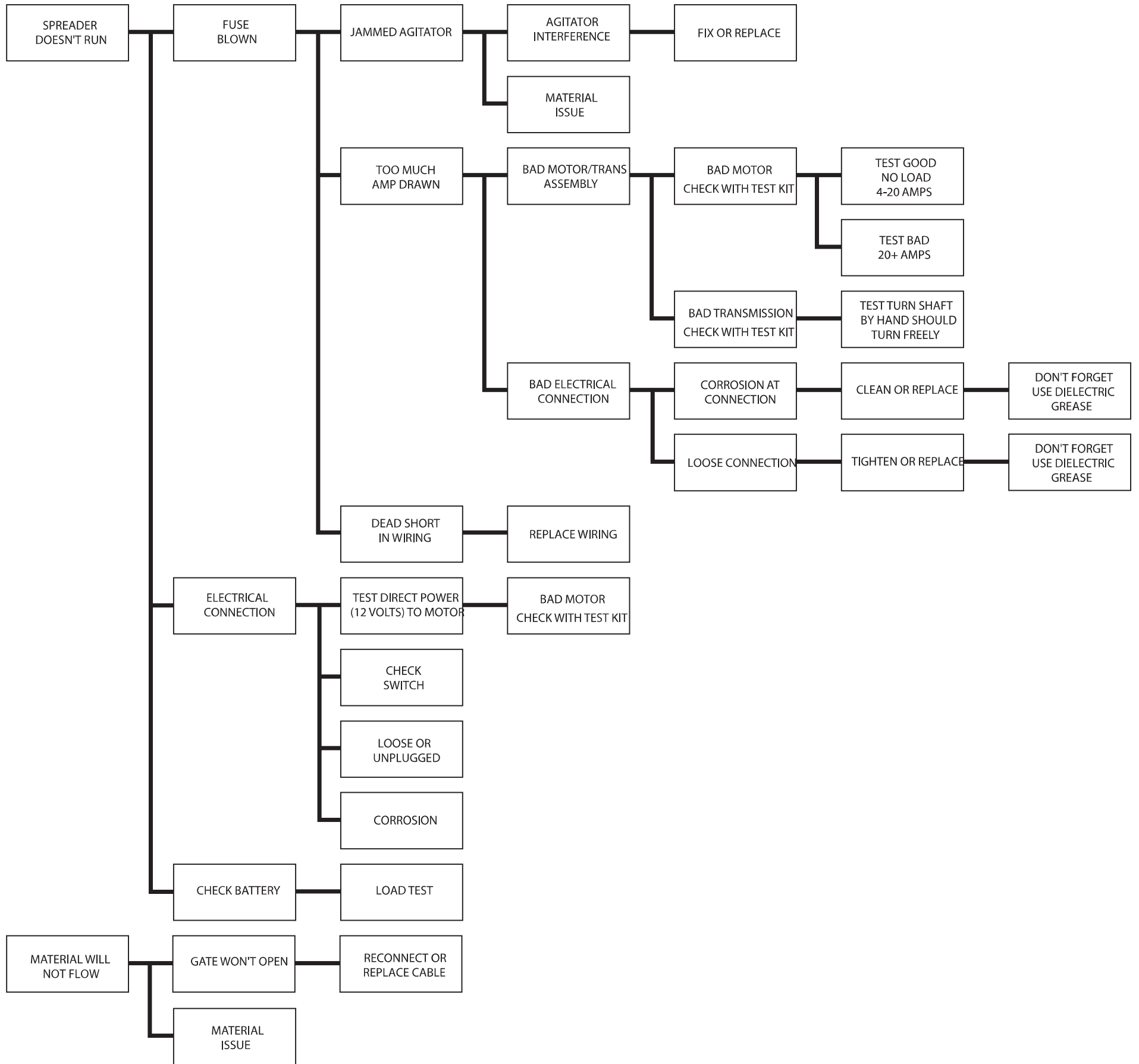

Warranty Registration and Customer Survey



To initiate the warranty on your new SnowEx spreader and assure prompt warranty service, please complete the following warranty registration and customer survey, sign and mail it back to the factory within 30 days of purchase.

- 1) Date of Purchase: _____
- 2) Name: _____
Address: _____

Phone: _____
- 3) SnowEx Model Purchased: _____ Serial Number: _____
- 4) Is this your first Trynex Spreader? Yes No
- 5) What type of vehicle are you using with your Spreader?
Make _____ Model _____ Year _____
- 6) What type of material are you using in your spreader? _____
- 7) SnowEx Dealer Name: _____
SnowEx Dealer Address: _____

SnowEx Dealer Phone: _____
- 8) Does your Trynex Dealer stock Trynex replacement Parts? Yes No I don't know
- 9) Do you feel your Trynex Dealer sold you the correct product for your needs/application? Yes No
- 10) How would you rate your overall satisfaction with your SnowEx Dealer?

<input type="checkbox"/>	<input type="checkbox"/>	<input type="checkbox"/>	<input type="checkbox"/>	<input type="checkbox"/>	<input type="checkbox"/>
Very Satisfied	Satisfied	Somewhat Satisfied	Somewhat Dissatisfied	Dissatisfied	Very Dissatisfied
- 11) How would you rate your overall satisfaction with your SnowEx Product?

<input type="checkbox"/>	<input type="checkbox"/>	<input type="checkbox"/>	<input type="checkbox"/>	<input type="checkbox"/>	<input type="checkbox"/>
Very Satisfied	Satisfied	Somewhat Satisfied	Somewhat Dissatisfied	Dissatisfied	Very Dissatisfied
- 12) Would you purchase another Trynex Product? Yes No
- 13) If you would like to receive **E-Mail ALERTS** for new products, bulletins or special promotions please supply address : _____
- 14) Please use the space below to convey your comments and/or suggestions.

- NOTE: I have read the owner's manual and all safety precautions and I understand that this equipment could be dangerous if not operated with care and under the proper conditions.
- 15) Owner's signature: **X** _____

PLEASE FOLD AND SEAL WITH TRANSPARENT TAPE BEFORE MAILING.